

BigToys[®] quick**Facts**: Internal Fastener

Threaded Insert Fastener

- Fastener commonly used in aircraft manufacturing industry
- ½" diameter, 33% larger than 3/8" fastener used by some competitors
- Eliminates the need for bulky external clamp connectors
- Pre-established connection points eliminate risk of unsafe conditions created through installation errors
- ½" connector holds up to 5,000 pounds per connection point
- Provides exceptional torque strength and vibration resistance

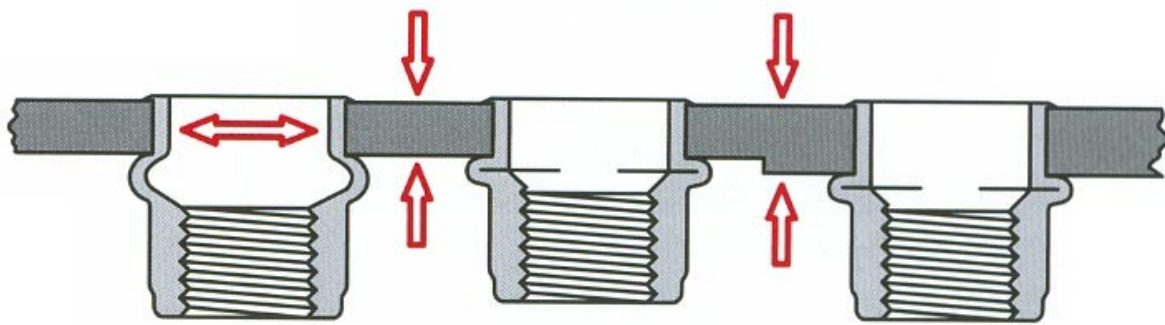

As the internal connector is tightened, the knurled body expands 360° filling hole.

The body of the threaded insert compresses as it is tightened, trapping the pipe wall between a backside flange and the low-profile head of the connector.